

FIREMAGIC®

ISLAND ENCLOSURE WHEEL KIT

Model # DC-WK-03

INSTALLER: Leave these instructions with consumer.
CONSUMER: Retain for future reference.

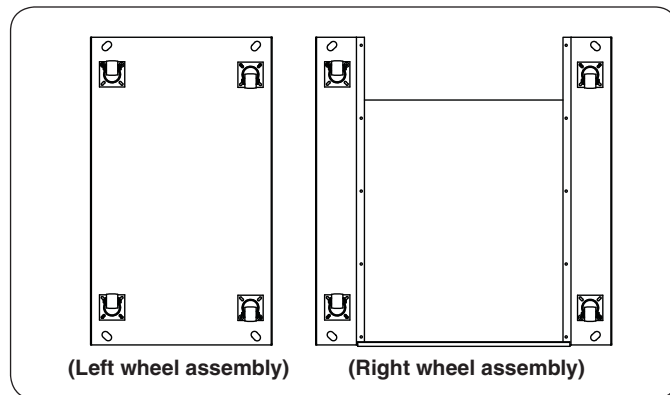

This wheel kit is only for installation on Fire Magic Island Enclosure models:

D(C,H)430-XX(R,D)-75XX

D(C,H)790-XX(R,D)-108XX

When using this wheel kit, set aside the levelers that are supplied with the GFCR Island.

Refrigerator (XXR) Models

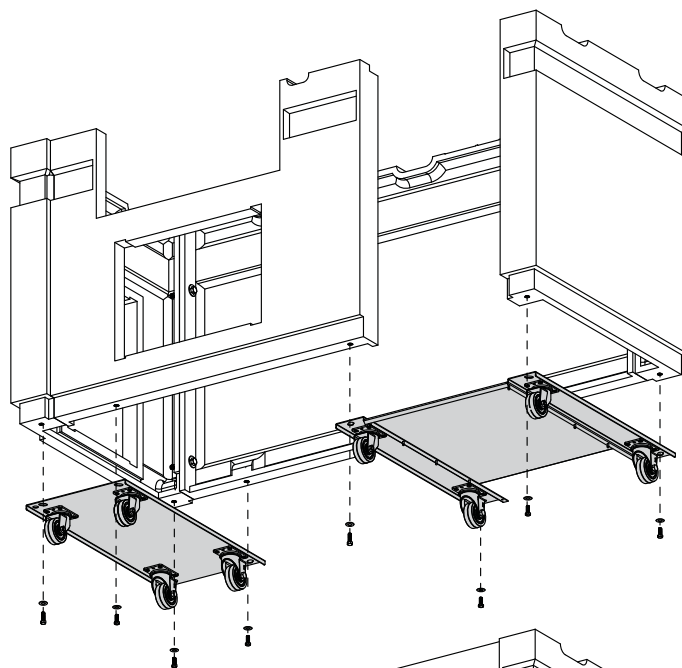

Note: Although island enclosure models vary by design, wheel kit and wheel kit installation is the same for all island enclosure models.

Drawer (XXD) Models

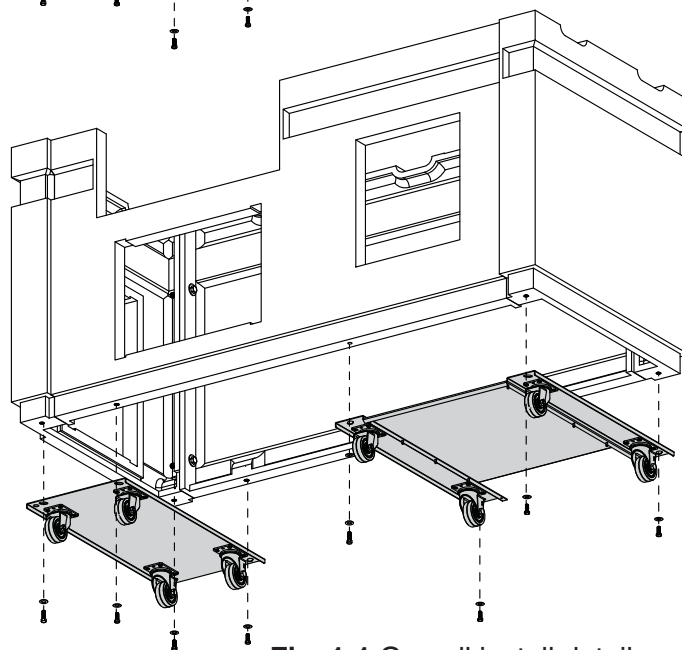

Fig. 1-1 Overall install detail

INSTALLATION

While assembling the island enclosure, install the wheel kit per the steps below. Follow the instructions supplied with the island for complete installation details.

Note: The wheel assemblies must stay level when being installed.

1. Align the left wheel assembly onto the left side wall and fasten using the included hardware and a $\frac{9}{16}$ " open-end wrench or equivalent. Hand tighten only. See Fig. 2-1.
2. Repeat for the rear wall using both wheel assemblies as shown in Fig. 2-2.
3. Repeat for the right side wall using the right wheel assembly as shown in Fig. 2-3.

Assembly continued on next page

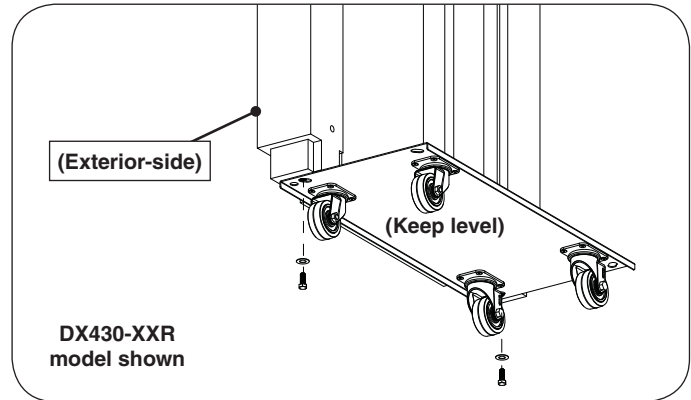

Fig. 2-1 Install left wheel assembly to bottom of left side wall

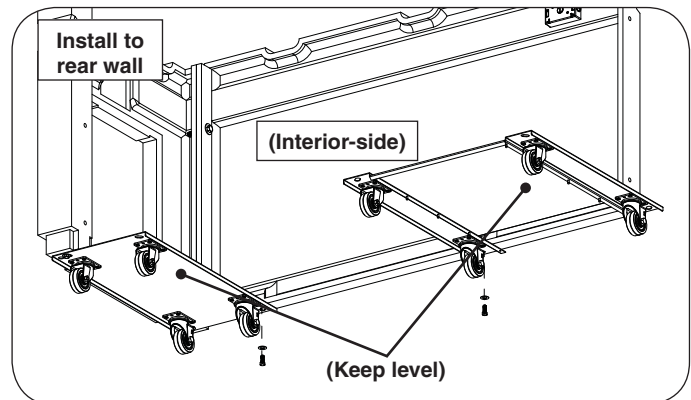

Fig. 2-2 Install wheel assemblies to bottom of rear wall

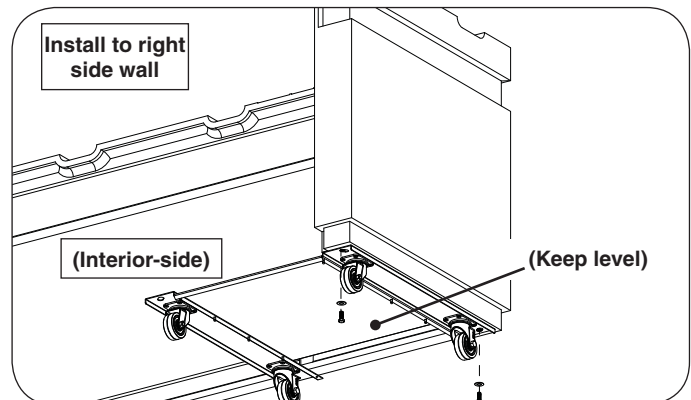

Fig. 2-3 Install right wheel assembly to bottom of right side wall

INSTALLATION (Cont.)

4. Repeat for the front wall using both wheel assemblies as shown in Fig. 3-1.
5. Refer to the island owner's manual to level, square, and fully tighten the island base.
6. **Once the wheel kits are installed, use one $\frac{9}{16}$ " open end wrench to fully tighten all hardware. DO NOT OVERTIGHTEN.**
7. **Follow your island owner's manual to complete island installation.**

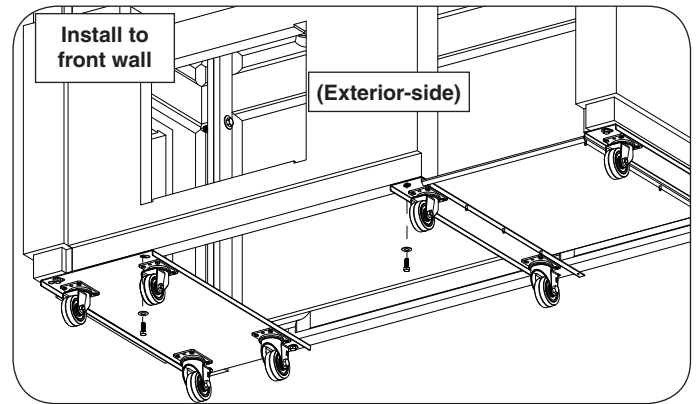

Fig. 3-1 Install wheel assemblies to bottom of front wall

